

RR-C-271E
23 December 2010
SUPERSEDING
RR-C-271D
25 September 1990

FEDERAL SPECIFICATION
CHAINS AND ATTACHMENTS, WELDED
AND WELDLESS

The General Services Administration has authorized the use of this federal specification by all federal agencies.

1. SCOPE AND CLASSIFICATION

1.1 Scope. This specification covers welded and weldless chain of commercial quality together with sundry attachments most commonly used with this chain.

1.1.1 Federal specification coverage. Federal specifications do not include all types, grades, classes, and styles of the commodities indicated by the title of the specification, or which are commercially available, but are intended to cover the types that are suitable for Federal Government requirements.

1.2 Classification. The welded and weldless chain and attachments are of the following types, classes, and styles as specified below (see 6.2).

1.2.1 Chain types. The types, classes, and styles of welded and weldless chain are as follows:

Type I - Chain, welded steel

- Class 1 - Alloy chain (overhead lift)
- Class 2 - High-test chain
- Class 4 - Proof-coil chain
- Class 5 - Twist-link chain

Style 1 - Long-link pattern (coil)

Style 2 - Short-link pattern (machine)

Beneficial comments, recommendations, additions, deletions, clarifications, etc. and any data that may improve this document should be sent to: STDZNMGT@dla.mil or Defense Logistics Agency Aviation VEB, 8000 Jefferson Davis Highway, Richmond, VA 23297-5616. Since contact information can change, you may want to verify the currency of this address information using the ASSIST database at <https://assist.daps.dla.mil/>.

Type II - Chain, weldless (forged and casting)

- Class 1 - Single-loop pattern chain
- Class 2 - Double-loop pattern chain
- Class 3 - Sash chain
- Class 4 - Flat-link chain
- Class 5 - Bead chain
- Class 6 - Plumber's chain
- Class 7 - Single-jack chain
- Class 8 - Double-jack chain
- Class 9 - Ladder chain
- Class 10 - Register chain
- Class 11 - Mechanical communication chain

1.2.2 Attachment types. Attachment types, grades, and classes are as follows:

- Type II - Connecting links
- Type III - Repair or end lap links
- Type IV - Shackles
- Type IVA - Anchor shackles

Grade A - Regular

- Class 1 - Round pin and cotter
- Class 2 - Screw pin
- Class 3 - Bolt, nut and cotter

Grade B - High strength

- Class 1 - Round pin and cotter
- Class 2 - Screw pin
- Class 3 - Bolt, nut and cotter

Type IVB - Chain shackles

Grade A - Regular

- Class 1 - Round pin and cotter
- Class 2 - Screw pin
- Class 3 - Bolt, nut and cotter

Grade B - High strength

- Class 1 - Round pin and cotter
- Class 2 - Screw pin
- Class 3 - Bolt, nut and cotter

Type V - Hooks

- Class 1 - Eye slip hooks
- Class 2 - Eye grab hooks
- Class 3 - Eye hoist or sling hooks
- Class 6 - Eye barrel hooks

Type VI - Rings

Type VII - Swivels

- Class 1 - Chain swivels
- Class 2 - Eye and eye swivels
- Class 3 - Jaw and eye swivels

Type IX - Bead chain fasteners

Type X - Bead chain couplings

Type XI - Bead chain insulating couplings

Type XIII - Pear-shaped links

Type XIV - Mechanical coupling links

Type XV - End links

2. APPLICABLE DOCUMENTS

2.1 Government publications. The issues of the following documents, in effect on the date of invitation for bids or request for proposal, form a part of this specification to the extent specified herein.

Federal Standards

- | | |
|-------------|---|
| FED-STD-H28 | - Screw-Thread Standards for Federal Services |
| FED-STD-123 | - Marking for Shipment (Civil Agencies) |

(Activities outside the federal government may obtain copies of federal specifications, standards, and commercial item descriptions as specified in the General Information section of the Index of Federal Specifications, Standards and Commercial Item Descriptions. The index is for sale on a subscription basis from the General Services Administration, Federal Supply Service, Specification Section, East 470 L'Enfant Plaza SW, Suite 8100, Washington, DC 20407.)

(Single copies of this specification, and other federal specifications, standards, and commercial item descriptions required by activities outside the federal government for bidding purposes are available without charge from the General Services Administration, Federal Supply Service, Specification Section, East 470 L'Enfant Plaza SW, Suite 8100, Washington, DC 20407.)

(Federal government activities may obtain copies of federal standardization documents and the Index of Federal Specifications, Standards and Commercial Item Descriptions from established distribution points in their agencies. Electronic copies may be obtained from <https://assist.daps.dla.mil/>.)

Military Standard

MIL-STD-2073-1 - Standard Practice for Military Packaging

(Copies of military specifications, standards, and handbooks required by contractors in connection with specific procurement functions are available from the Standardization Document Order Desk, Building 4D, 700 Robbins Avenue, Philadelphia, PA 19111-5094. Electronic copies may be obtained from <https://assist.daps.dla.mil/>.)

Federal Acquisition Regulation (FAR)

Subpart 23.4 - Use of Recovered Materials and Biobased Products

(The FAR is for sale on a subscription basis from the Superintendent of Documents, P.O. Box 371954, Pittsburgh, PA 15250-7954. When indicated, reprints of certain regulations may be obtained from the federal agency responsible for issuing them. Electronic copies may be obtained from <https://www.acquisition.gov/far/>.)

2.2 Other publications. The following documents form a part of this specification to the extent specified herein. Unless a specific issue is identified, the issue in effect on the date of invitation for bids or request for proposal shall apply.

American Society for Quality (ASQ)

ASQ Z1.4 - Sampling Procedures and Tables for Inspection by Attributes

(Copies of this document are available online at <http://www.asq.org/> or from American Society of Quality, 600 North Plankinton Avenue, Milwaukee, WI 53203.)

ASTM International

ASTM A143/A143M - Standard Practice for Safeguarding Against Embrittlement of Hot-Dip Galvanized Structural Steel Products and Procedure for Detecting Embrittlement

ASTM A153/A153M - Standard Specification for Zinc Coating (Hot-Dip) on Iron and Steel Hardware

ASTM A304 - Standard Specification for Carbon and Alloy Steel Bars Subject to End-Quench Hardenability Requirements

ASTM International - Continued

ASTM A322	- Standard Specification for Steel Bars, Alloy, Standard Grades
ASTM A391/A391M	- Standard Specification for Grade 80 Alloy Steel Chain
ASTM A413/A413M	- Standard Specification for Carbon Steel Chain
ASTM A466/A466M	- Standard Specification for Weldless Chain
ASTM A467/A467M	- Standard Specification for Machine and Coil Chain
ASTM A510	- Standard Specification for General Requirements for Wire Rods and Coarse Round Wire, Carbon Steel
ASTM A576	- Standard Specification for Steel Bars, Carbon, Hot-Wrought, Special Quality
ASTM A752	- Standard Specification for General Requirements for Wire Rods and Coarse Round Wire, Alloy Steel
ASTM A909/A909M	- Standard Specification for Steel Forgings, Microalloy, for General Industrial Use
ASTM A920/A920M	- Standard Specification for Steel Bars, Microalloy, Hot-Wrought, Special Quality, Mechanical Properties
ASTM A921/A921M	- Standard Specification for Steel Bars, Microalloy, Hot-Wrought, Special Quality, for Subsequent Hot Forging
ASTM A973/A973M	- Standard Specification for Grade 100 Alloy Steel Chain
ASTM B633	- Standard Specification for Electrodeposited Coatings of Zinc on Iron and Steel
ASTM B695	- Standard Specification for Coatings of Zinc Mechanically Deposited on Iron and Steel
ASTM D3951	- Standard Practice for Commercial Packaging

(Application for copies should be addressed to ASTM International, 100 Barr Harbor Drive, P.O. Box C700, West Conshohocken, PA 19428-2959. Electronic copies may be obtained from [http://www.astm.org/.](http://www.astm.org/))

2.3 Order of precedence. Unless otherwise noted herein or in the contract, in the event of a conflict between the text of this document and the references cited herein, the text of this document takes precedence. Nothing in this document, however, supersedes applicable laws and regulations unless a specific exemption has been obtained.

3. REQUIREMENTS

3.1 Material.

3.1.1 Type I chain, and various types of attachments, as indicated.

3.1.1.1 General. Unless otherwise specified, the material for type I chain and the indicated attachments and attachment parts shall conform to the chemical composition shown in table I.

TABLE I. Chemical composition.

Element	Maximum percent
Type I chain and type II, III, V, VI, and VIII attachments and attachment parts:	
Carbon	0.35 ¹
Phosphorus	0.05
Sulfur	0.05
Silicon	0.35
Type IV shackles:	
Carbon	0.45
Phosphorus	0.04
Sulfur	0.045
Silicon	0.35

¹ Steel with carbon 0.50 (maximum percent) is permitted for attachments or attachment parts (types II, III, V, VI, and VII) provided the fabrication is done without welding.

3.1.1.2 Type I Steel.

3.1.1.2.1 Type I, class 1 alloy chain; type V, class 1, 2, 3, and 6 hooks; type VI rings; type XIII pear-shaped links; and type XIV mechanical coupling links. Unless otherwise specified, type I, class 1 alloy chain; type V, class 1, 2, 3, and 6 hooks; type VI rings; type XIII pear-shaped links; and type XIV mechanical coupling links material shall be an alloy steel made in accordance with ASTM A322, ASTM A304, or ASTM A752. The chain and attachments shall be heat-treated, as required, to produce the physical requirements as specified.

3.1.1.2.2 Type I, class 2, high-test chain. Type I, class 2 high-test chain material shall be carbon steel made in accordance with ASTM A576 or ASTM A510. The chain shall be heat treated, as required, to produce the physical requirements specified.

3.1.1.2.3 Type I, classes 4 and 5, chain; type II, connecting links; type III, repair or end lap links; type VII, swivels; and type XV, end links. Type I, classes 4 and 5 chain; type II connecting links; type III repair or end lap links; type VII swivels; and type XV end links material shall be carbon steel made in accordance with ASTM A576 or ASTM A510. The chain and attachments shall be heat treated, as required, to produce the physical requirements specified.

3.1.1.2.4 Type IVA anchor shackles and type IVB chain shackles. Type IV, grade A shackles shall be made of carbon steel conforming to ASTM A576, ASTM A920/A920M, ASTM A909/A909M, or ASTM A921/A921M. Type IV, grade B shackles shall be made of alloy steel conforming to ASTM A322. The limitation in the chemical composition shall be as specified in table I.

3.1.2 Type II, classes 1, 2, 3, 4, 7, 8, 9, and 10 chain, weldless. Classes 1, 2, 3, 4, 7, 8, 9, and 10 shall be made of steel, bronze, or brass, as specified (see 6.2). Class 6 shall be made of steel, brass, or aluminum, as specified (see 6.2). Class 11 shall be made of brass.

3.1.3 Type II, class 5 bead chain; type IX bead-chain fasteners; type X bead-chain couplings; and type XI bead-chain insulating couplings. Type II, class 5 bead chain; type IX bead-chain fasteners; and type X bead-chain couplings shall be made of steel, corrosion resistant steel (CRES), or brass as specified (see 6.2). Type XI bead-chain insulating couplings shall have a hard fiber dielectric body fitted at each end with a metal cap made of steel, CRES, or brass as specified (see 6.2).

3.1.4 Recovered materials. The offeror/contractor is encouraged to use recovered materials to the maximum extent practicable, in accordance with paragraph 23.403 of the Federal Acquisition Regulation (FAR).

3.2 Finish.

3.2.1 General. The finish for chain and attachments shall be as specified (see 6.2). The following finishes for chain and attachments are typical.

- (a) Self-colored (chain uncoated, attachments cleaned and uncoated)
- (b) Bright finish (chain cleaned and uncoated)
- (c) Zinc-coated
- (d) Painted

3.2.1.1 Type I, chain, welded steel. Unless otherwise specified (see 6.2), the finish for type I, class 2, 4, and 5 shall be self-colored, bright finish, zinc coated or painted. The finish for type I, class 1 shall be bright finish or painted.

3.2.1.2 Type II, chain, weldless. Unless otherwise specified (see 6.2), the chain shall be zinc coated or self-colored.

3.2.1.3 Attachments. Unless otherwise specified (see 6.2), attachments, except type IV, shackles, hooks, and type VII swivels, shall be self-colored, painted or zinc coated. Unless otherwise specified, type IV shackles, hooks, and type VII swivels shall be zinc-coated.

3.2.1.4 Zinc coating. Where zinc coating is specified, the coating may be applied by the hot-dip (galvanizing) process, by the electrodeposition process, or by the mechanically deposited coating process at the contractor's option. If the hot-dip process is used, the coating shall be applied in accordance with ASTM A153/A153M, class B3; if the electrodeposition process is used, it shall be in accordance with ASTM B633, type II, class Fe/Zn 13; and if the mechanically deposited

coating process is used, it shall be in accordance with ASTM B695, type II, class 12. When the electrodeposition process is used, the coating shall be done on screw parts after threading and tapping is completed. When the hot-dip process is used, internal threads may be tapped or retapped after galvanizing. Zinc coating shall be adherent, smooth, and free from injurious defects.

3.2.1.4.1 Embrittlement. Where zinc coating of alloy steel is specified, the safeguarding against embrittlement and the procedure for detecting embrittlement shall be in accordance with ASTM A143/A143M.

3.3 Detail requirements - chain.

3.3.1 Type I, chain, welded steel.

3.3.1.1 Type I, class 1, welded steel alloy chain. The steel alloy chain shall be similar to figure 1 and shall be in accordance with ASTM A391/A391M or ASTM A973/A973M. The figures herein are descriptive, not restrictive, and are not intended to preclude the purchase of chain and attachments otherwise in accordance with this specification.

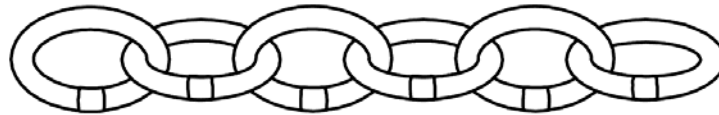

FIGURE 1. Type I, class 1, welded steel alloy chain.

3.3.1.2 Type I, class 2, welded steel high-test chain. The high test chain shall be similar to figure 2 and shall be in accordance with ASTM A413/A413M, grade 43.

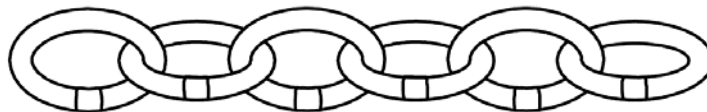

FIGURE 2. Type I, class 2, welded steel high-test chain.

3.3.1.3 Type I, class 4, welded steel proof-coil chain. The proof-coil chain shall be similar to figure 3 and shall be in accordance with ASTM A413/A413M, grade 30.

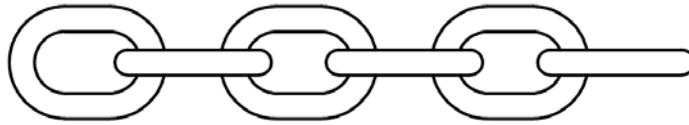

FIGURE 3. Type I, class 4, welded steel proof-coil chain.

3.3.1.4 Type I, class 5, style 1, welded steel twist-link chain, long-link pattern (coil). The long-link chain shall be similar to figure 4 and shall conform to the dimensions and physical requirements specified in ASTM A467/A467M, class CT.



FIGURE 4. Type I, class 5, style 1, welded steel twist-link chain, long-link pattern (coil).

3.3.1.5 Type I, class 5, style 2, welded steel twist-link chain, short-link pattern (machine). The short-link chain shall be similar to figure 5 and shall be in accordance with the dimensions and physical requirements as specified in ASTM A467/A467M, class MT.

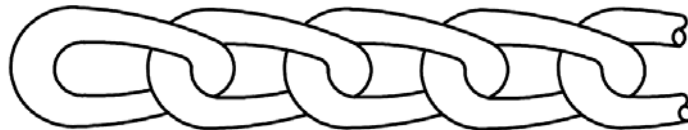

FIGURE 5. Type I, class 5, style 2, welded steel twist-link chain, short-link pattern (machine).

3.3.2 Type II, chain, weldless.

3.3.2.1 Class 1, single-loop pattern chain. The single-loop pattern chain shall be similar to figure 6 and shall be in accordance with ASTM A466/A466M, class SL.



FIGURE 6. Type II, class 1, weldless, single-loop pattern chain.

3.3.2.2 Class 2, double-loop pattern chain. The double-loop pattern chain shall be similar to figure 7 and shall be in accordance with ASTM A466/A466M, class DL.



FIGURE 7. Type II, class 2, weldless double-loop pattern chain.

3.3.2.3 Class 3, sash chain. The sash chain shall be similar to figure 8 and shall be in accordance with ASTM A466/A466M, class SH.



FIGURE 8. Type II, class 3, weldless sash chain.

3.3.2.4 Class 4, flat-link chain. The flat-link chain shall be similar to figure 9 and shall be in accordance with the requirements as shown in table II.



FIGURE 9. Type II, class 4, weldless flat-link chain.

TABLE II. Type II, class 4, weldless flat-link chain.

Nominal metal thickness (inch)	Number of links per foot (approx)	Weight per 100 feet (approx) (pounds)		Breaking load (min) ¹ (pounds)		Trade number
		Steel	Brass	Steel	Brass	
0.083	8.5	16	17	1,600	1,120	2-0
0.065	17	12.5	13	990	695	113
0.103	9.75	35	37	2,190	1,535	210
0.125	9	40	42	3,240	2,270	280

¹Maximum working load limit is 25 percent of breaking load.

3.3.2.5 Class 5, bead chain. The bead chain shall be similar to figure 10 and shall be in accordance with the requirements as shown in table III.



FIGURE 10. Type II, class 5, weldless bead chain.

TABLE III. Type II, class 5, weldless bead chain.

Nominal diameter of beads (approx) (inch)	Metal thickness (approx) (inch)	Number of beads per foot (approx)	Weight per 100 feet (approx) (pounds)	Breaking loads (min) (pounds)	Trade number
3/32	0.010	102	0.7	15	3
1/8	0.014	72	1.5	28	6
3/16	0.017	50	2.6	45	10
1/4	0.020	40	4.8	90	13
3/8	0.034	24	10.8	200	20

3.3.2.6 Class 6, plumber's chain. The plumber's chain shall be similar to figure 11 and shall be in accordance with ASTM A466/A466M, class SF.

FIGURE 11. Type II, class 6, weldless plumber's chain.

3.3.2.7 Class 7, single-jack chain. The single-jack chain shall be similar to figure 12 and shall be in accordance with ASTM A466/A466M, class SJ.

FIGURE 12. Type II, class 7, weldless single-jack chain.

3.3.2.8 Class 8, double-jack chain. The double-jack chain shall be similar to figure 13 and shall be in accordance with ASTM A466/A466M, class DJ.

FIGURE 13. Type II, class 8, weldless double-jack chain.

3.3.2.9 Class 9, ladder chain. The ladder chain shall be similar to figure 14 and shall be in accordance with the requirements as shown in table IV.

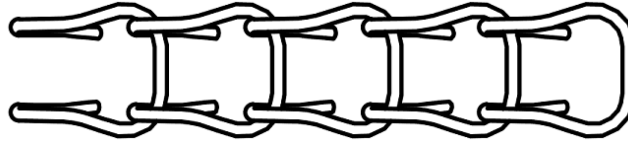

FIGURE 14. Type II, class 9, weldless ladder chain.

TABLE IV. Type II, class 9, weldless ladder chain.

Nominal size of chain (inch)	Number of links per foot (approx)	Weight per 100 feet (approx) (pounds)	Breaking loads (min) (pounds)	
			Steel	Brass or bronze
0.036	64	0.8	45	40
0.048	42	2.5	70	60
0.055	34	3.5	85	75
0.080	25	6	145	130

3.3.2.10 Class 10, register chain. The register chain shall be similar to figure 15 and shall be in accordance with ASTM A466/A466M, class RG.

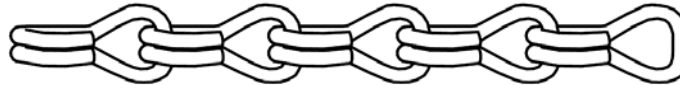

FIGURE 15. Type II, class 10, weldless register chain.

3.3.2.11 Class 11, mechanical communication chain. The mechanical communication chain shall be similar to figure 16 and shall be in accordance with the requirements as shown in table V.

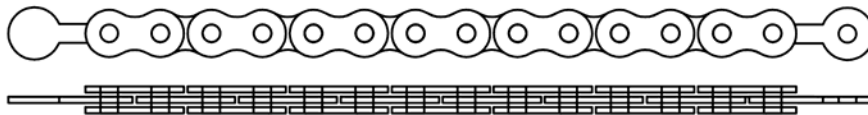

FIGURE 16. Type II, class 11, weldless mechanical communication chain.

TABLE V. Type II, class 11, weldless mechanical communication chain.

Nominal thickness outside links (inch)	Nominal thickness inside links (inch)	Width (max) (inch)	Pitch (center-to-center) of pins (approx)	Number of links per foot (approx)	Breaking load (min) (pounds)
1/16	1/8	0.25	0.375	32	800

3.3.2.11.1 End links. Each end of the completed chain shall be fitted with a large brass link for the attachment of transmission wires.

3.3.2.11.2 Length. The total length of the finished chain shall be approximately 30 inches.

3.4 Detail requirements - attachments.

3.4.1 Type II, connecting links. Connecting links shall be forged from carbon steel as specified in 3.1.1.2.3, shall be similar to figure 17, and shall be in accordance with the dimensions and physical requirements as shown in table VI. The 3/16, 1/4, and 5/16-inch sizes shall have rivets only, no interlocking lugs.

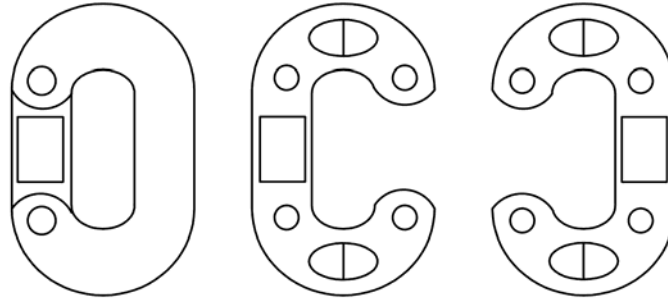

FIGURE 17. Type II, connecting links.

TABLE VI. Type II, connecting links.

Trade size (nom) (inch)	Outside dimensions of links (L x W) (approx) (inches)	Weight per dozen (approx) (pounds)	Working load limit (pounds)	Proof load (min) (pounds)	Breaking loads (min) (pounds)
3/16	1.25 x 0.75	0.375	750	1,500	3,000
1/4	1.5 x 1	0.75	1,250	2,500	5,000
5/16	1.688 x 1.188	1	1,900	3,800	7,600
3/8	2.062 x 1.375	2	2,650	5,300	10,600
7/16	2.375 x 1.5	3.125	3,625	7,250	14,500
1/2	2.625 x 1.75	4.5	4,500	9,000	18,000
9/16	3 x 1.938	6.625	5,800	11,600	23,200
5/8	3.312 x 2.188	9	6,900	13,800	27,600
3/4	3.875 x 2.5	14.5	9,750	19,500	39,000
7/8	4.5 x 2.938	20.25	12,000	24,000	48,000
1	5 x 3.25	29	15,500	31,000	62,000
1-1/8	5.625 x 3.5	40	19,500	39,000	78,000
1-1/4	6.125 x 4	53.5	24,000	48,000	96,000
1-3/8	6.75 x 4.75	75	28,750	57,500	115,000
1-1/2	7.25 x 5.125	103	34,000	68,000	136,000
1-5/8	8 x 5.5	131	42,000	84,000	168,000
1-7/8	9 x 6.25	216	64,000	128,000	256,000

3.4.2 Type III, repair or end lap links. End lap links shall be formed from carbon steel as specified in 3.1.1.2.3. Links shall be of the end lap type, shall be similar to figure 18, and shall be in accordance with the dimensions and weights as shown in table VII.

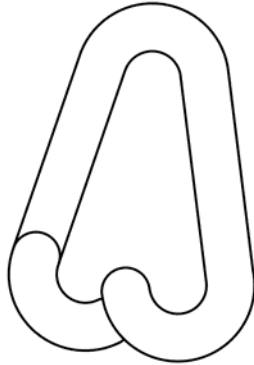

FIGURE 18. Type III, repair or end lap link.

TABLE VII. Type III, repair or end lap links.

Diameter of metal (inches)	Length inside (nom) (inches)	Working load limit (pounds)	Weight per 100 links (approx) (pounds)	Breaking load (min) (pounds)
0.188	1	225	5	900
0.219	1.25	250	5.75	1,000
0.25	1.25	325	7.2	1,300
0.25	1.5	325	9	1,300
0.25	2	325	10.25	1,300
0.281	1.25	375	9.3	1,500
0.312	1.5	675	14.5	2,700
0.312	2	625	17	2,500
0.375	1.625	1,050	22	4,200
0.375	2	1,000	25	4,000
0.5	2.5	1,525	54	6,100

3.4.3 Type IV, shackles.

3.4.3.1 General. Type IV, grade A shackles shall be forged from carbon steel as specified in 3.1.1.2.4. Pins and bolts for grade A shackles shall be made from carbon or alloy steel as specified in 3.1.1.2.4. Type IV, grade B shackles, together with their pins and bolts, shall be forged from alloy steel as specified in 3.1.1.2.4.

3.4.3.1.1 Threads. Screw-pin shackles shall be threaded after fabrication to final size and shape. Threads shall conform to FED-STD-H28 for Unified Coarse (UNC) threads unless the corresponding fine threads are specified (see 6.2). Threads on finished shackles shall be not looser than class 1 fit. The male threads of zinc-coated shackles may be undercut, as necessary,

so that after coating they will properly mate (not less than class 1 fit) with the standard size female threads, or the inside threads may be similarly oversized.

3.4.3.1.2 Proof loads. Shackles shall withstand the proof loads shown in table VIII (see 4.4.2.2.1) without developing surface rupture or defects that would interfere with serviceability or prevent disassembly of the pin. After proof loading, screw-pin shackles shall be disassembled by hand after the first turn.

TABLE VIII. Mechanical properties.

Size (D) (nominal) (inches)	Working load limit (pounds)		Proof load (min) (pounds)		Breaking load (min) (pounds)	
	Grade A	Grade B	Grade A	Grade B	Grade A	Grade B
3/16	650	1,000	1,430	2,200	3,250	5,000
1/4	1,000	1,500	2,200	3,300	5,000	7,500
5/16	1,500	2,500	3,300	5,500	7,500	12,500
3/8	2,000	4,000	4,400	8,800	10,000	20,000
7/16	3,000	5,200	6,600	11,440	15,000	26,000
1/2	4,000	6,600	8,800	14,520	20,000	33,000
9/16	5,000	8,000	11,000	17,600	25,000	40,000
5/8	6,500	10,000	14,300	22,000	32,500	50,000
3/4	9,500	14,000	20,900	30,800	47,500	70,000
7/8	13,000	19,000	28,600	41,800	65,000	95,000
1	17,000	25,000	37,400	55,000	85,000	125,000
1-1/8	19,000	30,000	41,800	66,000	95,000	150,000
1-1/4	24,000	36,000	52,800	79,200	120,000	180,000
1-3/8	27,000	42,000	59,400	92,400	135,000	210,000
1-1/2	34,000	60,000	74,800	132,000	170,000	300,000
1-5/8	40,000	70,000	88,000	154,000	200,000	350,000
1-3/4	50,000	80,000	110,000	176,000	250,000	400,000
2	70,000	100,000	154,000	220,000	350,000	500,000
2-1/4	80,000	120,000	176,000	264,000	400,000	600,000
2-1/2	110,000	160,000	242,000	352,000	550,000	800,000
2-3/4	120,000	180,000	264,000	396,000	600,000	900,000
3	170,000	220,000	374,000	484,000	850,000	1,100,000
3-1/2	240,000	280,000	528,000	616,000	1,200,000	1,400,000
4	300,000	350,000	660,000	770,000	1,500,000	1,750,000

3.4.3.1.3 Breaking loads. Shackles shall meet the breaking load requirements shown in table VIII (see 4.4.2.2.2).

3.4.3.1.4 Working load limit. The working load limits (WLL) of shackles covered by this specification are shown in table VIII.

3.4.3.1.5 Ductility. Shackles shall be sufficiently ductile so that, when fractured, the fractured member shall show a permanent distortion before breaking. If the pin fractures, it shall show a permanent bend of not less than 20 degrees. If the body fractures, it shall show a permanent mid-shackle set of not less than 15 percent of the original spread between bows.

3.4.3.1.6 Marking. Each shackle body shall be permanently and legibly marked in raised or stamped letters on the side of the shackle bow with the identifying manufacturer's name or trademark, shackle size, and the WLL. As a minimum, all shackle pins and bolts shall be marked with the manufacturer's mark or symbol; in addition, all grade B shackle pins and bolts shall be marked with the raised or stamped letters "HS" on the head. Shackle markings shall be raised or stamped letters or figures of the maximum practical height permitted by the size of the shackle component being marked, but not to exceed 0.75 inch in height by 0.125 inch in relief. Stamping dies shall be of the round bottom, low-stress type. Marking location shall not interfere with the serviceability of the shackle assembly.

3.4.3.1.7 Finish. Unless otherwise specified (see 6.2), shackle components shall be zinc coated as specified in 3.2.1.4.

3.4.3.2 Form and dimensions. The form of the respective shackle types and classes shall be similar to that shown on figures 19 and 20 (see 6.2). Except for reference dimensions, the dimensions of shackle bodies and component pins and bolts shall conform to the dimensional requirements specified in tables IX, X, XI, XII, XIII, and XIV. Reference dimensions are for information only.

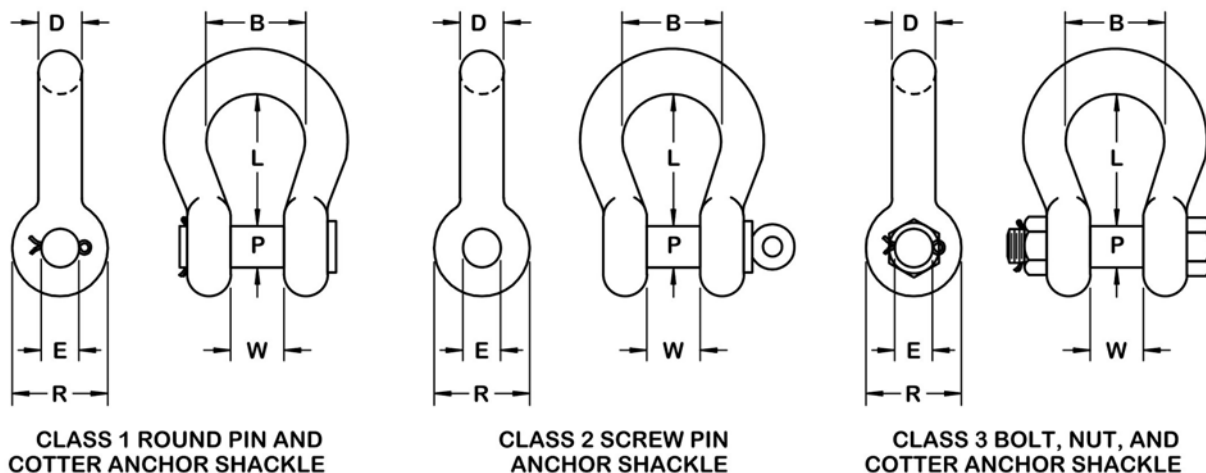

FIGURE 19. Type IV, grade A, anchor shackles.

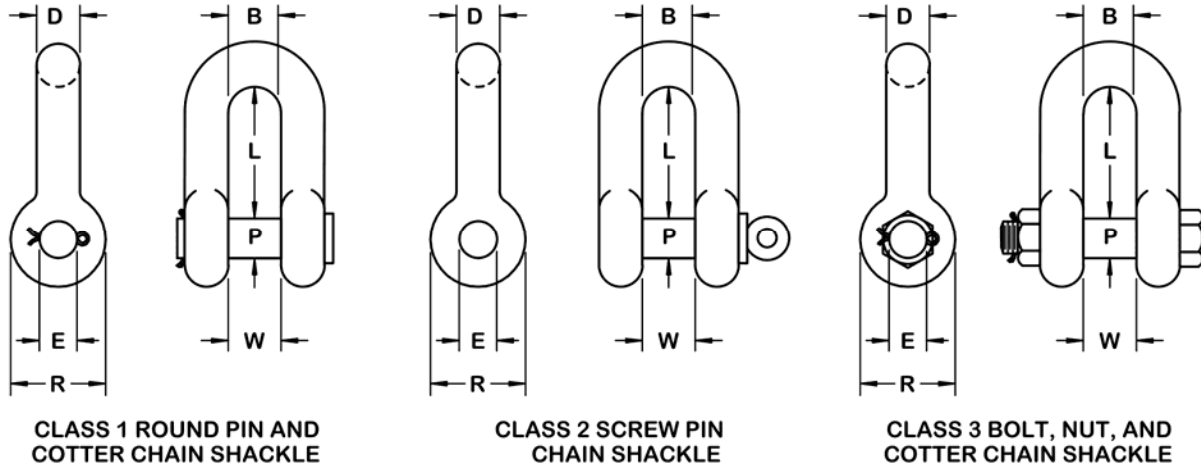

FIGURE 20. Type IV, grade B, chain shackles.

TABLE IX. Type IV, grade A, class 1, round pin and cotter anchor shackles.

Trade size (nom) (inches)	Dimension (D) (min) (inches)	Diameter pin (P) (min) (inches)	Diameter inside eye (E) (ref) (inches)	Width between eyes (W) \pm nominal tolerance (inches)	Length inside (L) \pm nominal tolerance (inches)	Width bow (B) (min) (inches)	Diameter outside eye (R) (max) (inches)	Weight per 100 shackles (approx) (pounds)
3/16	0.18	0.240	0.297	0.375 \pm 0.125	0.875 \pm 0.062	0.562	0.625	5
1/4	0.24	0.300	0.406	0.469 \pm 0.125	1.125 \pm 0.062	0.75	0.875	12
5/16	0.30	0.365	0.469	0.531 \pm 0.125	1.250 \pm 0.062	0.812	1	18
3/8	0.36	0.430	0.531	0.656 \pm 0.125	1.438 \pm 0.125	0.938	1.125	30
7/16	0.42	0.490	0.594	0.750 \pm 0.125	1.688 \pm 0.125	1.062	1.25	49
1/2	0.48	0.610	0.719	0.812 \pm 0.125	1.875 \pm 0.125	1.188	1.375	74
9/16	0.53	0.610	0.719	0.875 \pm 0.125	2.125 \pm 0.125	1.375	1.625	92
5/8	0.59	0.730	0.844	1.062 \pm 0.125	2.375 \pm 0.125	1.5	1.875	144
3/4	0.71	0.850	0.969	1.250 \pm 0.125	2.812 \pm 0.250	1.75	2.125	216
7/8	0.83	0.980	1.094	1.438 \pm 0.125	3.312 \pm 0.250	2	2.375	337
1	0.95	1.100	1.219	1.688 \pm 0.125	3.75 \pm 0.25	2.312	2.625	530
1-1/8	1.07	1.220	1.344	1.812 \pm 0.125	4.25 \pm 0.25	2.625	2.875	700
1-1/4	1.19	1.340	1.469	2.031 \pm 0.125	4.688 \pm 0.25	2.875	3.25	960
1-3/8	1.31	1.460	1.625	2.250 \pm 0.188	5.25 \pm 0.25	3.25	3.5	1,260
1-1/2	1.42	1.580	1.75	2.375 \pm 0.188	5.75 \pm 0.25	3.375	3.75	1,730
1-5/8	1.54	1.710	1.875	2.625 \pm 0.188	6.25 \pm 0.25	4	4.125	2,200
1-3/4	1.66	1.950	2.156	2.875 \pm 0.188	7.00 \pm 0.25	4.5	4.5	2,780
2	1.90	2.190	2.406	3.250 \pm 0.188	7.75 \pm 0.50	5.25	5.25	4,110
2-1/4	2.14	2.440	2.656	3.875 \pm 0.188	9.25 \pm 0.50	5.5	5.75	5,600
2-1/2	2.38	2.680	2.906	4.125 \pm 0.250	10.50 \pm 0.50	6.75	6.25	8,350
3	2.85	3.170	3.406	5.00 \pm 0.25	13.00 \pm 0.75	7.375	6.75	11,900
3-1/2	3.32	3.660	3.906	5.25 \pm 0.25	15.00 \pm 0.75	9	8.5	21,200
4	3.8	4.140	4.406	5.50 \pm 0.25	14.50 \pm 0.75	10.5	9.5	30,500

TABLE X. Type IV, grade A, class 2, screw pin anchor shackles.

Trade size (nom) (inches)	Dimension (D) (min) (inch)	Diameter pin (P) (min) (inches)	Diameter unthreaded eye (E) (ref) (inches)	Width between eyes (W) ± nom tolerance (inches)	Length inside (L) ± nom tolerance (inches)	Width bow (B) (min) (inches)	Major dia. threaded eye (ref) (inches)	Dia. outside eye (R) (max) (inches)	Weight per 100 shackles (approx) (pounds)
3/16	0.18	0.24	0.312	0.375 ±0.125	0.875 ±0.062	0.562	0.281	0.625	5
1/4	0.24	0.30	0.406	0.469 ±0.125	1.125 ±0.062	0.75	0.344	0.875	12
5/16	0.30	0.37	0.469	0.531 ±0.125	1.250 ±0.062	0.812	0.406	1	18
3/8	0.36	0.43	0.531	0.656 ±0.125	1.438 ±0.125	0.938	0.469	1.125	30
7/16	0.42	0.49	0.594	0.750 ±0.125	1.688 ±0.125	1.062	0.531	1.25	49
1/2	0.48	0.61	0.719	0.812 ±0.125	1.875 ±0.125	1.188	0.656	1.375	74
9/16	0.53	0.61	0.719	0.875 ±0.125	2.125 ±0.125	1.375	0.656	1.625	92
5/8	0.59	0.73	0.844	1.062 ±0.125	2.375 ±0.125	1.5	0.781	1.875	144
3/4	0.71	0.85	0.969	1.250 ±0.125	2.812 ±0.250	1.75	0.906	2.125	216
7/8	0.83	0.98	1.094	1.438 ±0.125	3.312 ±0.250	2	1.031	2.375	337
1	0.95	1.10	1.219	1.688 ±0.125	3.75 ±0.25	2.312	1.156	2.625	530
1-1/8	1.07	1.22	1.344	1.812 ±0.125	4.25 ±0.25	2.625	1.297	2.875	700
1-1/4	1.19	1.34	1.469	2.031 ±0.125	4.688 ±0.250	2.875	1.422	3.25	960
1-3/8	1.31	1.46	1.625	2.250 ±0.188	5.25 ±0.25	3.25	1.547	3.5	1,260
1-1/2	1.42	1.58	1.75	2.375 ±0.188	5.75 ±0.25	3.375	1.672	3.75	1,730
1-5/8	1.54	1.71	1.875	2.625 ±0.188	6.25 ±0.25	4	1.797	4.125	2,200
1-3/4	1.66	1.95	2.156	2.875 ±0.188	7.00 ±0.25	4.5	2.047	4.5	2,780
2	1.90	2.19	2.406	3.250 ±0.188	7.75 ±0.50	5.25	2.297	5.25	4,110
2-1/4	2.14	2.44	2.656	3.875 ±0.188	9.25 ±0.50	5.5	2.547	5.75	5,600
2-1/2	2.38	2.68	2.906	4.125 ±0.250	10.50 ±0.50	6.75	2.797	6.25	8,350
3	2.85	3.17	3.406	5.00 ±0.25	13.00 ±0.75	7.375	3.297	6.75	11,900
3-1/2	3.32	3.66	3.906	5.25 ±0.25	15.00 ±0.75	9	3.797	8.5	21,200
4	3.80	4.14	4.406	5.50 ±0.25	14.50 ±0.75	10.5	4.297	9.5	30,500

TABLE XI. Type IV, grade A, class 3, bolt, nut and cotter anchor shackles.

Trade size (nom) (inches)	Dimension (D) (min) (inch)	Diameter bolt (P) (min) (inches)	Diameter inside eye (E) (ref) (inches)	Width between eyes (W) \pm nom tolerance (inches)	Length inside (L) \pm nom tolerance (inches)	Width bow (B) (min) (inches)	Diameter outside eye (R) (max) (inches)	Weight per 100 shackles (approx) (pounds)
3/16	0.18	0.24	0.297	0.375 \pm 0.125	0.875 \pm 0.062	0.562	0.625	5
1/4	0.24	0.30	0.406	0.469 \pm 0.125	1.125 \pm 0.062	0.75	0.875	12
5/16	0.30	0.37	0.469	0.531 \pm 0.125	1.250 \pm 0.062	0.812	1	18
3/8	0.36	0.43	0.531	0.656 \pm 0.125	1.438 \pm 0.125	0.938	1.125	30
7/16	0.42	0.49	0.594	0.750 \pm 0.125	1.688 \pm 0.125	1.062	1.25	49
1/2	0.48	0.61	0.719	0.812 \pm 0.125	1.875 \pm 0.125	1.188	1.375	82
5/8	0.53	0.61	0.844	1.062 \pm 0.125	2.375 \pm 0.125	1.5	1.875	158
3/4	0.59	0.73	0.969	1.250 \pm 0.125	2.812 \pm 0.250	1.75	2.125	280
7/8	0.71	0.85	1.094	1.438 \pm 0.125	3.312 \pm 0.250	2	2.375	395
1	0.83	0.98	1.219	1.688 \pm 0.125	3.75 \pm 0.25	2.312	2.625	560
1-1/8	0.95	1.10	1.344	1.812 \pm 0.125	4.25 \pm 0.25	2.625	2.875	785
1-1/4	1.07	1.22	1.469	2.031 \pm 0.125	4.688 \pm 0.250	2.875	3.25	1,120
1-3/8	1.19	1.34	1.625	2.250 \pm 0.188	5.25 \pm 0.25	3.25	3.5	1,520
1-1/2	1.31	1.46	1.75	2.375 \pm 0.188	5.75 \pm 0.25	3.375	3.75	1,950
1-5/8	1.42	1.58	1.875	2.625 \pm 0.188	6.25 \pm 0.25	4	4.125	2,410
1-3/4	1.54	1.71	2.156	2.875 \pm 0.188	7.00 \pm 0.25	4.5	4.5	3,130
2	1.66	1.95	2.406	3.250 \pm 0.188	7.75 \pm 0.50	5.25	5.25	4,630
2-1/4	1.90	2.19	2.656	3.875 \pm 0.188	9.25 \pm 0.50	5.5	5.75	5,650
2-1/2	2.14	2.44	2.906	4.125 \pm 0.250	10.50 \pm 0.5	6.75	6.25	9,400
2-3/4	2.38	2.68	3.156	4.50 \pm 0.25	11.25 \pm 0.50	7.25	6.25	11,500
3	2.85	3.17	3.406	5.00 \pm 0.25	13.00 \pm 0.75	7.375	6.75	14,500
3-1/2	3.32	3.66	3.906	5.50 \pm 0.25	15.00 \pm 0.75	9	8.5	26,500
4	3.8	4.14	4.406	6.50 \pm 0.25	17.00 \pm 0.75	10.5	9.5	35,800

TABLE XII. Type IV, grade B, class 1, round pin and cotter chain shackles.

Trade size (nom) (inches)	Dimension (D) (min) (inch)	Diameter pin (P) (min) (inches)	Diameter inside eye (E) (ref) (inches)	Width between eyes (W) \pm nom tolerance (inches)	Length inside (L) \pm nom tolerance (inches)	Diameter outside eye (R) (max) (inches)	Weight per 100 shackles (approx) (pounds)
3/16	0.18	0.240	0.312	0.375 \pm 0.125	0.750 \pm 0.062	0.625	5
1/4	0.24	0.300	0.406	0.469 \pm 0.125	0.875 \pm 0.062	0.875	11
5/16	0.30	0.365	0.469	0.531 \pm 0.125	1.031 \pm 0.062	1	17
3/8	0.36	0.430	0.531	0.656 \pm 0.125	1.250 \pm 0.125	1.125	28
7/16	0.42	0.490	0.594	0.750 \pm 0.125	1.438 \pm 0.125	1.25	42
1/2	0.48	0.610	0.719	0.812 \pm 0.125	1.625 \pm 0.125	1.375	68
9/16	0.53	0.610	0.719	0.875 \pm 0.125	1.812 \pm 0.125	1.625	88
5/8	0.59	0.730	0.844	1.062 \pm 0.125	2.000 \pm 0.125	1.875	121
3/4	0.71	0.850	0.969	1.250 \pm 0.125	2.375 \pm 0.250	2.125	214
7/8	0.83	0.980	1.094	1.438 \pm 0.125	2.812 \pm 0.250	2.375	310
1	0.95	1.100	1.219	1.688 \pm 0.125	3.188 \pm 0.250	2.625	450
1-1/8	1.07	1.220	1.344	1.812 \pm 0.125	3.562 \pm 0.250	2.875	660
1-1/4	1.19	1.340	1.469	2.031 \pm 0.125	3.938 \pm 0.250	3.25	890
1-3/8	1.31	1.460	1.625	2.250 \pm 0.188	4.438 \pm 0.250	3.5	1,200
1-1/2	1.42	1.580	1.75	2.375 \pm 0.188	4.875 \pm 0.250	3.75	1,620
1-5/8	1.54	1.710	1.875	2.625 \pm 0.188	5.25 \pm 0.25	4.125	2,020
1-3/4	1.66	1.950	2.156	2.875 \pm 0.188	5.75 \pm 0.25	4.5	2,500
2	1.90	2.190	2.406	3.250 \pm 0.188	6.75 \pm 0.50	5.25	3,600
2-1/4	2.14	2.440	2.656	3.875 \pm 0.188	7.125 \pm 0.500	5.75	5,000
2-1/2	2.38	2.680	2.906	4.125 \pm 0.250	8.0 \pm 0.5	6.25	7,400
3	2.85	3.170	3.406	5.00 \pm 0.25	9.00 \pm 0.75	6.75	10,600
3-1/2	3.32	3.660	3.906	5.25 \pm 0.25	10.50 \pm 0.75	8.5	18,900
4	3.8	4.140	4.406	5.50 \pm 0.25	12.00 \pm 0.75	9.5	27,100

TABLE XIII. Type IV, grade B, class 2, screw pin chain shackles.

Trade size (nom) (inches)	Dimension (D) (min) (inch)	Diameter pin (P) (min) (inches)	Diameter unthreaded eye (E) (ref) (inches)	Width between eyes (W) \pm nom tolerance (inches)	Length inside (L) \pm nom tolerance (inches)	Major dia. threaded eye (ref) (inches)	Dia. outside eye (R) (max) (inches)	Weight per 100 shackles (approx) (pounds)
3/16	0.18	0.24	0.312	0.375 \pm 0.125	0.750 \pm 0.062	0.281	0.625	5
1/4	0.24	0.30	0.406	0.469 \pm 0.125	0.875 \pm 0.062	0.344	0.875	11
5/16	0.30	0.37	0.469	0.531 \pm 0.125	1.031 \pm 0.062	0.406	1	17
3/8	0.36	0.43	0.531	0.656 \pm 0.125	1.125 \pm 0.125	0.469	1.25	28
7/16	0.42	0.49	0.594	0.750 \pm 0.125	1.438 \pm 0.125	0.531	1.25	42
1/2	0.48	0.61	0.719	0.812 \pm 0.125	1.625 \pm 0.125	0.656	1.375	68
9/16	0.53	0.61	0.719	0.875 \pm 0.125	1.812 \pm 0.125	0.656	1.625	88
5/8	0.59	0.73	0.844	1.062 \pm 0.125	2.000 \pm 0.125	0.781	1.875	121
3/4	0.71	0.85	0.969	1.250 \pm 0.125	2.375 \pm 0.250	0.906	2.125	214
7/8	0.83	0.98	1.094	1.438 \pm 0.125	2.812 \pm 0.250	1.031	2.375	310
1	0.95	1.10	1.219	1.688 \pm 0.125	3.188 \pm 0.250	1.156	2.625	450
1-1/8	1.07	1.22	1.344	1.812 \pm 0.125	3.562 \pm 0.250	1.297	2.875	660
1-1/4	1.19	1.34	1.469	2.031 \pm 0.125	3.938 \pm 0.250	1.422	3.25	890
1-3/8	1.31	1.46	1.625	2.250 \pm 0.188	4.438 \pm 0.250	1.547	3.5	1,200
1-1/2	1.42	1.58	1.75	2.375 \pm 0.188	4.875 \pm 0.250	1.672	3.75	1,620
1-5/8	1.54	1.71	1.875	2.625 \pm 0.188	5.25 \pm 0.25	1.797	4.125	2,020
1-3/4	1.66	1.95	2.156	2.875 \pm 0.188	5.75 \pm 0.25	2.047	4.5	2,500
2	1.90	2.19	2.406	3.250 \pm 0.188	6.75 \pm 0.50	2.297	5.25	3,600
2-1/4	2.14	2.44	2.656	3.875 \pm 0.188	7.125 \pm 0.500	2.547	5.75	5,000
2-1/2	2.38	2.68	2.906	4.125 \pm 0.250	8.0 \pm 0.5	2.797	6.25	7,400
3	2.85	3.17	3.406	5.00 \pm 0.25	9.00 \pm 0.75	3.297	6.75	10,600
3-1/2	3.32	3.66	3.906	5.25 \pm 0.25	10.50 \pm 0.75	3.797	8.5	18,900
4	3.8	4.14	4.406	5.50 \pm 0.25	12.00 \pm 0.75	4.297	9.5	27,100

TABLE XIV. Type IV, grade B, class 3, bolt, nut and cotter chain shackles.

Trade size (nom) (inches)	Dimension (D) (min) (inch)	Diameter bolt (P) (min) (inches)	Diameter inside eye (E) (ref) (inches)	Width between eyes (W) (inches)	Length inside (L) (inches)	Diameter outside eye (R) (max) (inches)	Weight per 100 shackles (approx) (pounds)
3/16	0.18	0.24	0.312	0.375 ±0.125	0.750 ±0.062	0.625	5
1/4	0.24	0.30	0.406	0.469 ±0.125	0.875 ±0.062	0.875	11
5/16	0.30	0.37	0.469	0.531 ±0.125	1.031 ±0.062	1	17
3/8	0.36	0.43	0.531	0.656 ±0.125	1.250 ±0.125	1.125	28
7/16	0.42	0.49	0.594	0.750 ±0.125	1.438 ±0.125	1.25	42
1/2	0.48	0.61	0.719	0.812 ±0.125	1.625 ±0.125	1.375	76
5/8	0.59	0.73	0.844	1.062 ±0.125	2.000 ±0.125	1.875	156
3/4	0.71	0.85	0.969	1.250 ±0.125	2.375 ±0.250	2.125	262
7/8	0.83	0.98	1.094	1.438 ±0.125	2.812 ±0.250	2.375	365
1	0.95	1.10	1.219	1.688 ±0.125	3.188 ±0.250	2.625	535
1-1/8	1.07	1.22	1.344	1.812 ±0.125	3.562 ±0.250	2.875	727
1-1/4	1.19	1.34	1.469	2.031 ±0.125	3.938 ±0.250	3.25	1,020
1-3/8	1.31	1.46	1.625	2.250 ±0.188	4.438 ±0.250	3.5	1,335
1-1/2	1.42	1.58	1.75	2.375 ±0.188	4.875 ±0.250	3.75	1,850
1-5/8	1.54	1.71	1.875	2.625 ±0.188	5.25 ±0.25	4.125	2,310
1-3/4	1.66	1.95	2.156	2.875 ±0.188	5.75 ±0.25	4.5	2,850
2	2.14	2.44	2.406	3.250 ±0.188	6.75 ±0.50	5.25	4,110
2-1/2	2.38	2.68	2.906	4.125 ±0.250	8.0 ±0.5	6.25	8,450
3	2.85	3.17	3.406	5.00 ±0.25	9.00 ±0.75	6.75	12,300
3-1/2	3.32	3.66	3.906	5.25 ±0.25	10.5 ±0.75	8.5	21,800
4	3.8	4.14	4.406	5.50 ±0.25	12.00 ±0.75	9.5	31,000

3.4.4 Type V, hooks. The hooks shall be forged from alloy steel as specified in 3.1.1.2.1. Class 1, 2, 3, and 6 hooks shall be used with type I alloy chain.

3.4.4.1 Ductility. The class 1, 2, and 3 hooks shall be sufficiently ductile to permit the hook to open to at least twice the original throat gap without fracture.

3.4.4.1.1 Finish. Class 1, 2, and 3 hooks shall be zinc coated as specified in 3.2.1.4.

3.4.4.2 Class 1, eye slip hook. The eye slip hooks shall have the eye parallel to the hook, shall be similar to figure 21, and shall be in accordance with the physical requirements as shown in table XV.

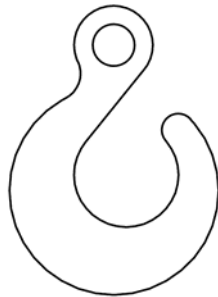

FIGURE 21. Type V, class 1, eye slip hook.

TABLE XV. Type V, class 1, eye slip hook.

Size of chain (nominal) (inch)	Weight each (approx) (pounds)	Working load limit (pounds)	Proof load (min) (pounds)	Breaking load (min) (pounds)
1/4	0.4	3,600	7,200	14,400
3/8	1.0	6,400	12,800	25,600
1/2	2.5	11,400	22,800	45,600
5/8	3.1	17,800	35,600	71,200
3/4	6.0	25,650	51,300	102,600

3.4.4.3 Class 2, eye grab hooks. The eye grab hooks shall have the eye parallel to the hook, shall be similar to figure 22, and shall be in accordance with the physical requirements as shown in table XVI.



FIGURE 22. Type V, class 2, eye grab hook.

TABLE XVI. Type V, class 2, eye grab hook.

Size of chain (nominal) (inch)	Weight each (approx) (pounds)	Working load limit (pounds)	Proof load (min) (pounds)	Breaking load (min) (pounds)
1/4	0.44	3,600	7,200	14,400
3/8	1.1	6,400	12,800	25,600
1/2	2.3	11,400	22,800	45,600
5/8	4.0	17,800	35,600	71,200
3/4	6.1	25,650	51,300	102,600

3.4.4.4 Class 3, eye hoist or eye sling hooks. The eye hoist or eye sling hooks shall have the eye parallel to the hook, shall be similar to figure 23, and shall be in accordance with physical requirements as shown in table XVII.

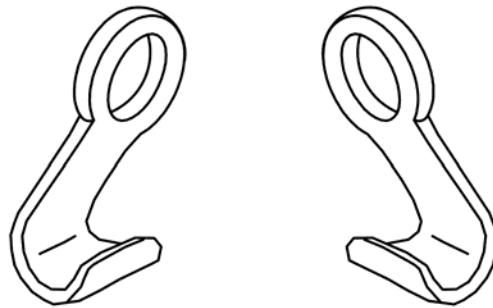

FIGURE 23. Type V, class 3, eye hoist or eye sling hook.

TABLE XVII. Type V, class 3, eye hoist or eye sling hooks.

Size of chain (nominal) (inch)	Weight each (approx) (pounds)	Working load limit (pounds)	Proof load (min) (pounds)	Breaking load (min) (pounds)
1/4	0.7	3,600	7,200	14,400
3/8	1.5	6,400	12,800	25,600
1/2	3.0	11,400	22,800	45,600
5/8	5.1	17,800	35,600	71,200
3/4	8.0	25,650	51,300	102,600
7/8	11.0	34,900	69,800	139,600
1	18.0	45,600	91,200	182,400
1-1/4	33.0	71,250	142,500	285,000

3.4.4.5 Class 6, eye barrel hooks. The eye barrel hooks shall be similar to figure 24, and shall be made with a nominal overall length of 5 inches. The hooks shall be tested to a proof load of 5,500 pounds (see 4.4.2.3.1).

FIGURE 24. Type V, class 6, eye barrel hook.

3.4.5 Type VI, rings. The rings shall be forged or welded from low alloy steel and shall be in accordance with the chemical requirements as shown in table I. The rings shall be heat treated, be similar to figure 25, and shall be accordance with the sizes and weights as shown in table XVIII.

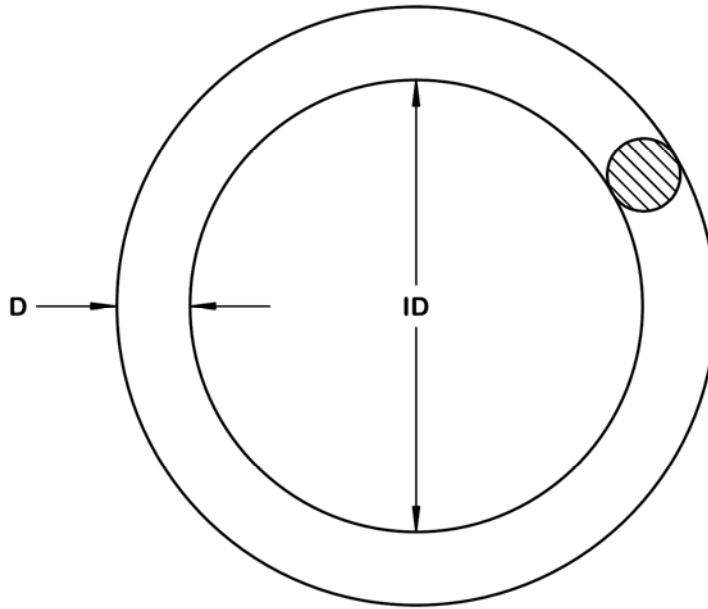
FIGURE 25. Type VI, ring.TABLE XVIII. Type VI, rings.

Diameter stock (D) (nom) (inches)	Inside diameter (ID) (nom) (inches)	Weight each (approx) (pounds)	Working load limit (pounds)	Proof load (min) (pounds)	Breaking load (min) (pounds)
0.75	4	1.8	6,400	12,800	38,400
0.875	4	2.6	7,200	14,400	43,200
0.875	5.5	3.4	5,600	11,200	33,600
1	4	3.5	10,800	21,600	64,800
1.125	6	6.5	10,400	20,800	62,400
1.25	7	6.8	17,000	34,000	102,000
1.375	6	10.38	19,000	38,000	114,000
1.5	6	11.7	34,900	69,800	209,400

3.4.5.1 Finish. Rings shall be zinc coated as specified in 3.2.1.4.

3.4.6 Type VII, swivels.

3.4.6.1 General. Type VII swivels, together with their pins, shall be forged from carbon steel as specified in 3.1.1.2.3. Nuts shall be regular hexagonal.

3.4.6.1.1 Finish. The swivels and pins shall be zinc coated in accordance with 3.2.1.4.

3.4.6.1.2 Proof load. The swivels shall withstand the proof loads in the respective class tables (see 4.4.2.5.1).

3.4.6.1.3 Breaking load. The swivels shall withstand, without breaking, breaking loads shown in the respective class tables (see 4.4.2.5.1).

3.4.6.2 Type VII, class 1, chain swivels. The chain swivels shall be similar to figure 26 and shall be in accordance with the dimensions and physical requirements as shown in table XIX.

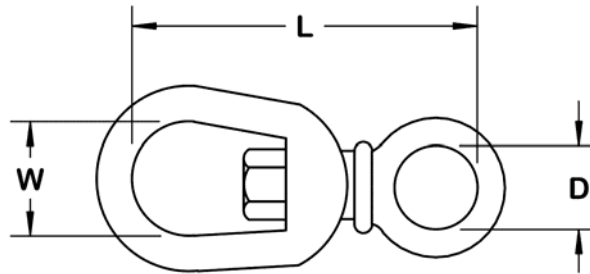

FIGURE 26. Type VII, class 1, chain swivel.

TABLE XIX. Type VII, class 1, chain swivels.

Trade size (nom) (inch)	Length (L) (min) (inch)	Width (W) (nom) (inches)	Eye dia. (D) (min)	Weight per 100 (approx) (pounds)	Working load limit (pounds)	Proof load (min) (pounds)	Breaking load (min) (pounds)
1/4	2.25	0.75	0.438	13	800	1,600	4,000
5/16	2.719	1	0.5	25	1,200	2,400	6,000
3/8	3.438	1.25	0.75	50	2,200	4,400	11,000
1/2	4.25	1.5	0.875	100	3,500	7,000	17,500
5/8	5.125	1.75	1.062	175	5,200	10,400	26,000
3/4	5.781	2	1.25	287	7,100	14,200	35,500

3.4.6.3 Class 2, eye and eye swivels. The eye and eye swivels shall be similar to figure 27, and shall be in accordance with the dimensions and physical requirements as shown in table XX.

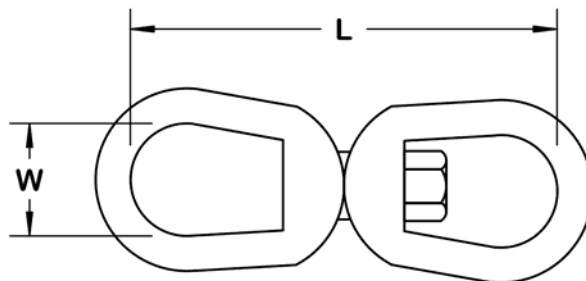

FIGURE 27. Type VII, class 2, eye and eye swivel.

TABLE XX. Type VII, class 2, eye and eye swivels.

Trade size (nom) (inch)	Length (L) (min) (inch)	Width (W) (nom) (inches)	Weight per 100 (approx) (pounds)	Working load limit (pounds)	Proof load (min) (pounds)	Breaking load (min) (pounds)
1/4	2.875	0.75	17.5	800	1,600	4,000
5/16	3.5	1	32.5	1,200	2,400	6,000
3/8	4.25	1.25	63	2,200	4,400	11,000
1/2	5.438	1.5	132	3,500	7,000	17,500
5/8	6.562	1.75	250	5,200	10,400	26,000
3/4	7.188	2	375	7,100	14,200	35,500
7/8	8.375	2.25	600	9,200	18,400	46,000
1	9.625	2.5	900	11,600	23,200	56,200
1-1/8	10.375	2.75	1,246	15,000	30,000	75,000
1-1/4	11.125	3.125	1,637	18,000	36,000	90,000
1-1/2	16.688	4	4,906	45,000	90,000	225,000

3.4.6.4 Class 3, jaw and eye swivels. The jaw and eye swivels shall be similar to figure 28, and shall be in accordance with the dimensions and physical requirements as shown in table XXI.

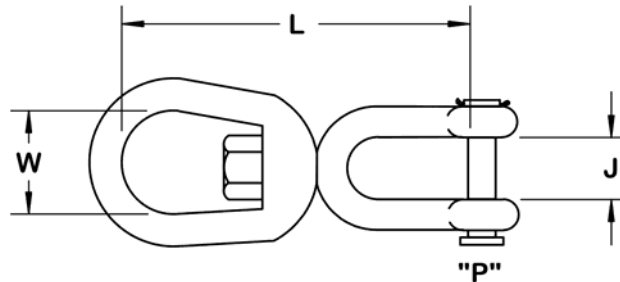
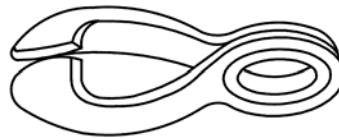

FIGURE 28. Type VII, class 3, jaw and eye swivel.

TABLE XXI. Type VII, class 3, jaw and eye swivels.

Trade size (nom) (inch)	Length (L) (min) (inch)	Width (W) (nom) (inch)	Jaw opening (J) (min) (inch)	Pin dia. (P) (min) (inch)	Weight per 100 (approx) (pounds)	Working load limit (pounds)	Proof load (min) (pounds)	Breaking load (min) (pounds)
1/4	2.438	0.75	0.469	0.25	21	800	1,600	4,000
5/16	2.812	1	0.5	0.312	34	1,200	2,400	6,000
3/8	3.5	1.25	0.625	0.375	62	2,200	4,400	11,000
1/2	4.5	1.5	0.75	0.5	125	3,500	7,000	17,500
5/8	5.312	1.75	0.938	0.625	235	5,200	10,400	26,000
3/4	6.062	2	1.125	0.75	350	7,100	14,200	35,500
7/8	7	2.25	1.188	0.875	575	9,200	18,400	46,000
1	8.25	2.5	1.75	1.125	950	11,600	23,200	56,200
1-1/8	8.938	2.75	1.75	1.125	1,100	15,000	30,000	75,000
1-1/4	9.438	3.125	2.062	1.375	1,575	18,000	36,000	90,000
1-1/2	14.25	4	2.875	2.25	5,475	45,000	90,000	225,000

3.4.7 Type IX, bead-chain fasteners (standard couplings with eyelets). The bead-chain fasteners shall be made of brass, corrosion resistant steel (CRES), or steel, shall be similar to figure 29, and shall be in accordance with the dimensions and physical requirements as shown in table XXII.

FIGURE 29. Type IX, bead-chain fastener.TABLE XXII. Type IX, bead-chain fasteners.

Trade no.	Size of chain used with (inch)	Length overall (approx) (inches)	Diameter of hole in eye (approx) (inch)	Weight per 100 couplings (approx) (pounds)
6 - AD	1/8	0.406	0.125	0.100
10 - A	3/16	0.5	0.125	0.187
10 - AD	3/16	0.562	0.188	0.250
13 - AN	1/4	0.688	0.188	0.312
20 - A	3/8	1.031	0.25	1.320

3.4.8 Type X, bead chain couplings. The bead-chain couplings shall be made of brass, CRES, or steel, shall be similar to figure 30, and shall be in accordance with the dimensions and physical requirements as shown in table XXIII.

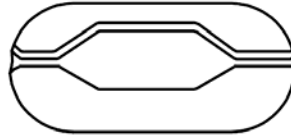

FIGURE 30. Type X, bead-chain coupling.

TABLE XXIII. Type X, bead-chain couplings.

Trade no.	Size of chain used with (inch)	Length overall (approx) (inches)	Ring wire size (max) (inch)	Weight per 100 couplings (approx) (pounds)
3-L	3/32	0.375	-	0.0386
6-L	1/8	0.5	-	0.085
10-B	3/16	0.531	0.125	0.150
13-B	1/4	0.688	0.141	0.420

3.4.9 Type XI, bead-chain insulating couplings. The bead-chain insulating couplings shall be as shown on figure 31, and shall be in accordance with the dimensions and physical requirements shown in table XXIV. The couplings shall have a hard fiber body fitted at each end with a metal cap that shall have a hole and slot to receive bead chain. The couplings shall withstand dielectric strength tests (see 4.4.2.6).

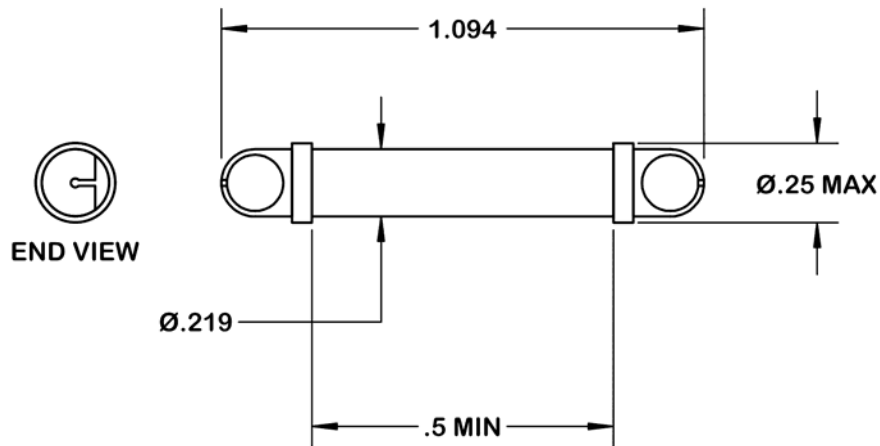

FIGURE 31. Type XI, bead-chain insulating coupling.

TABLE XXIV. Type XI, bead-chain insulating coupling.

Size of chain used with (inch)	Length overall (approx) (inches)	Distance between metal ends (min) (inch)	Diameter of fiber rod (approx) (inch)	Breaking load (min) (pounds)
1/8	1.094	0.5	0.219	25

3.4.10 Type XIII, pear-shaped links. The pear-shaped links shall be forged or welded from low alloy steel and shall be in accordance with chemical requirements shown in table I. The links shall be heat treated, be similar to figure 32, and shall be in accordance with the sizes and weights as shown in table XXV.

FIGURE 32. Type XIII, pear-shaped link.

TABLE XXV. Type XIII, pear-shaped links.

Nominal diameter (A) (inches)	Inside widths		Inside length (D) (approx) (inches)	Working load limit (pounds)	Proof load (min) (pounds)	Breaking load (min) (pounds)	Weight each (approx) (pounds)
	(B) (min) (inches)	(C) (min) (inches)					
1/2	1	2	3	3,600	7,200	14,400	0.8
5/8	1.25	2.5	3.75	6,250	12,500	25,000	1.4
3/4	1.5	2.75	4.5	9,000	18,000	36,000	2.1
7/8	1.75	3	5.25	11,400	22,800	45,600	2.8
1	2	3.5	6	16,000	32,000	64,000	4.6
1-1/4	2.5	4.375	7.75	25,650	51,300	102,600	9.0
1-3/8	2.75	5	8.25	30,750	61,500	123,000	11.5
1-1/2	3	5.25	10.5	34,900	69,800	139,600	15.3

3.4.10.1 Finish. The pear-shaped links shall be zinc coated in accordance with 3.2.1.4.

3.4.11 Type XIV, mechanical coupling links. The mechanical coupling links shall be forged from alloy steel as specified in 3.1.1.2.1, shall be similar to figure 33, and shall be in accordance with the dimensions and physical requirements as shown in table XXVI.

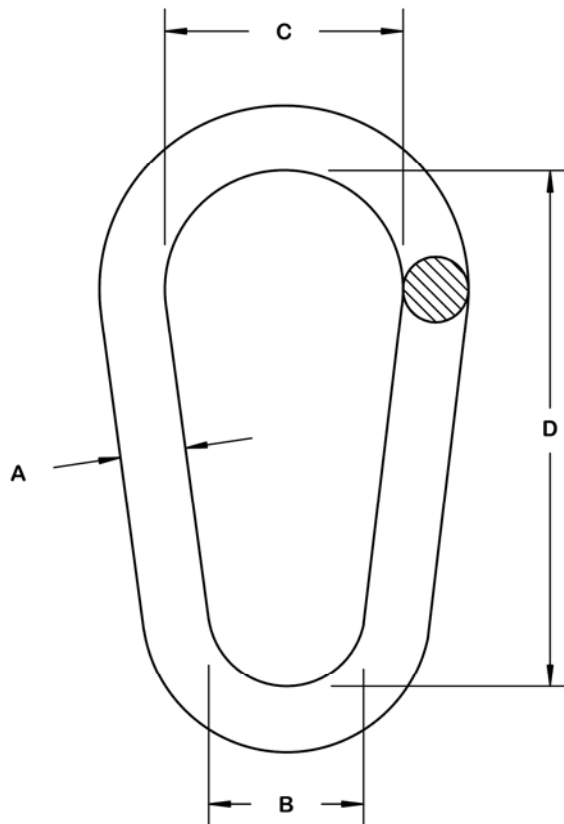
FIGURE 33. Type XIV, mechanical coupling link.

TABLE XXVI. Type XIV, mechanical coupling links.

Chain size (nom) (inch)	Dimensions (inches)								Weight each (approx) (pounds)	Working load limit (pounds)	Proof load (min) (pounds)	Breaking load (min) (pounds)
	(A)		(B)		(C)		(D)					
	min	max	min	max	min	max	min	max				
9/32	0.312	0.34	1.81	2.25	0.625	0.81	0.58	0.656	0.24	4,100	8,200	16,400
5/16	0.38	0.42	2.13	2.32	0.83	0.89	0.68	0.83	0.35	5,100	10,200	20,400
3/8	0.437	0.52	2.406	2.75	0.828	1.15	0.812	0.921	0.50	7,100	14,200	28,400
1/2	0.58	0.64	3.16	3.75	1.20	1.42	1.031	1.312	1.3	13,000	26,000	52,000
5/8	0.75	0.81	3.906	4.062	1.50	1.64	1.281	1.593	2.3	20,300	40,600	81,200
3/4	0.875	0.96	4.62	4.81	1.77	2.02	1.562	1.875	4.0	29,300	58,600	117,200
7/8	1.00	1.13	5.312	5.97	2.031	2.45	1.781	2.281	4.3	39,900	79,800	159,600
1	1.116	1.38	5.75	6.50	2.187	2.75	2.031	2.625	8.4	47,700	95,400	190,800
1-1/4	1.45	1.70	6.937	8.28	2.812	3.61	2.281	3.125	15.5	72,300	144,600	289,200

3.4.12 Type XV, end links. The end links shall be forged from carbon or alloy steel conforming, respectively, to ASTM A576 or ASTM A322, and the limitation in chemical composition shall be as specified in table I; the links shall be heat treated, weldless, and similar to figure 34; and the links shall be in accordance with the dimensions and physical requirements as shown in table XXVII.

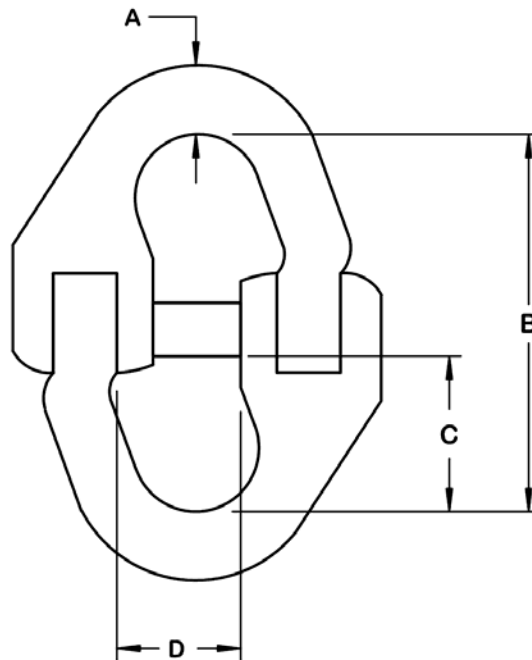
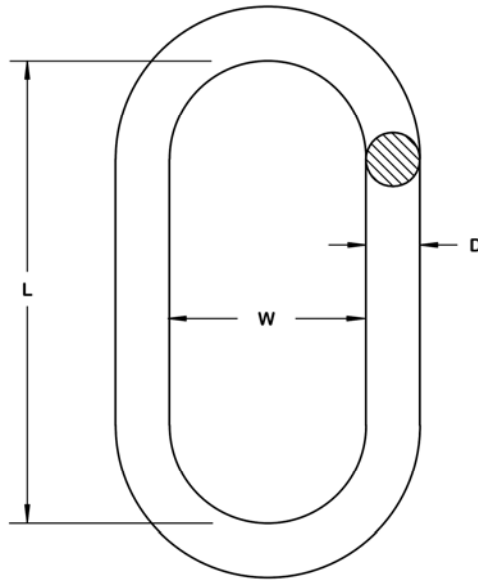

FIGURE 34. Type XV, end link.

TABLE XXVII. Type XV, end links.

Diameter (nom) (inches)	Inside length (nom) (inches)	Inside width (nom) (inches)	Weight each (approx) (pounds)	Proof load (min) (pounds)	Breaking load (min) (pounds)
0.625	3.25	1	0.95	7,070	14,150
0.75	3.5	1.125	1.51	11,050	22,100
0.875	5.125	2	2.75	15,900	31,800
1	4	1.5	3.95	50,000	95,000

3.4.12.1 Finish. Links shall be zinc coated as specified in 3.2.1.4.

3.5 Workmanship. The chain and attachments shall be free from injurious imperfections and defects that may impair appearance or serviceability. The forged and welded chain and attachments shall be free from fins, cracks, flaws, or seams. The screw threads shall be true to form, clean cut, and free from injurious defects.

4. QUALITY ASSURANCE PROVISIONS

4.1 Responsibility for inspection. Unless otherwise specified in the contract, the contractor is responsible for the performance of all inspection requirements as specified herein. Except as otherwise specified in the contract, the contractor may use his own or any other facilities suitable for the performance of the inspection requirements specified herein, unless disapproved by the government. The government reserves the right to perform any of the inspections set forth in the specification where such inspections are deemed necessary to assure that supplies and services conform to prescribed requirements.

4.1.1 Responsibility for compliance. All items shall meet all requirements of sections 3 and 5. The inspections set forth in this specification shall become a part of the contractor's overall inspection system or quality program. The absence of any inspection requirements in the specification shall not relieve the contractor of the responsibility of ensuring that all products or supplies submitted to the Government for acceptance comply with all requirements of the contract. Sampling inspection, as part of the manufacturing operations, is an acceptable practice to ascertain conformance to requirements, however, this does not authorize submission of known defective material, either indicated or actual, nor does it commit the Government to accept defective material.

4.2 Conformance inspection. Conformance inspection shall consist of the examinations and tests as specified in 4.3 and 4.4.

4.2.1 Lot.

4.2.1.1 Type I, chain. For the purpose of inspection, a lot shall be in accordance with ASTM A391/A391M, ASTM A973/A973M, ASTM A413/A413M, and ASTM A467/A467M.

4.2.1.2 Type II, chain. Except for class 9, 10, and 11, and for the purpose of inspection, a lot shall be in accordance with ASTM A466/A466M.

4.2.1.3 Attachments. For the purpose of inspection, a lot shall consist of not more than 10,000 attachments made from the same material, of the same type and class, offered for delivery at one time.

4.2.2 Sampling procedures.

4.2.2.1 Chain.

4.2.2.1.1 Visual and dimensional inspection. A portion of each lot of chain shall be selected for visual and dimensional inspection. If lots comprise more than one length of chain, the sample links shall be selected equally from each lot.

4.2.2.1.2 Types I and II. A random sample of chain not less than two feet long shall be selected from each lot for inspection. Every link in the sample shall be visually examined for conformance to the requirements of this specification.

4.2.2.1.3 Breaking and elongation test. A specimen not less than two feet long, cut from the finished chain, shall be selected from each lot to undergo breaking and elongation tests specified in 4.4.1.1 and 4.4.1.2.

4.2.2.2 Attachments.

4.2.2.2.1 Sampling for inspection and proof load. A random sample of attachments for visual inspection and proof load shall be selected from each lot, except insulated couplings, in accordance with ASQ Z1.4, inspection level 2, with the Acceptance Quality Limit (AQL) as specified in the contract (see 6.2).

4.2.2.2.2 Sampling for breaking and ductility tests. A sample of attachments shall be randomly selected in accordance with table XXVIII for the breaking and ductility tests specified in 4.4.2.

TABLE XXVIII. Sampling for inspection and testing of attachments.

Number of attachments per lot	Number to be selected for breaking load and ductility tests
2 to 8	2
9 to 15	2
16 to 25	2
26 to 50	2
51 to 90	3
91 to 150	3
151 to 280	3
281 to 500	3
501 to 1,200	5
1,201 to 3,200	5
3,201 to 10,000	5

4.2.2.2.3 Type XI, bead chain insulating couplings. The number of representative samples shall be selected from each lot as shown in table XXIX for the dielectric strength test as specified in 4.4.2.6.

TABLE XXIX. Sampling procedure for type XI, bead chain insulating couplings.

Number of couplings per lot	Number of samples to be selected for dielectric strength test
1 to 50	2
51 to 1,000	4
1,001 to 10,000	10

4.2.2.2.4 Chemical analysis. Steel chemistry of material for chain and attachments shall be determined from the certified mill data sheet or by analysis of either bars or from finished chain or attachments.

4.3 Examination.

4.3.1 Chain. Each sample of chain selected as specified in 4.2.2.1 shall be examined to determine conformance to this specification regarding dimensions, finish, quality of welds, and other requirements. Chain shall be measured to the inside of the end links after the chain has been proof tested.

4.3.2 Attachments. A random sample of attachments as specified in 4.2.2.2 shall be examined to determine conformance to this specification regarding dimensions, finish, quality of welds, and other requirements. If attachments are to be zinc coated, surface inspection shall be made before and after coating. Proof and breaking tests shall be made after zinc coating.

4.3.3 Rejections.

4.3.3.1 Chain. If the inspection sample fails to meet the requirements as specified in 4.3.1, the lot shall be rejected.

4.3.3.2 Attachments. Sample attachments failing to conform to the requirements specified in 4.3.2 shall be rejected. If any defects are noted in the original sample attachments, additional attachments shall be randomly selected as specified in the original sampling plan, and if any defects are noted, the entire lot shall be rejected.

4.4 Tests.

4.4.1 Chain.

4.4.1.1 Breaking test. Breaking tests shall be performed in accordance with ASTM A391/A391M, ASTM A413/A413M, ASTM A466/A466M, or ASTM A467/A467M, as appropriate.

4.4.1.2 Elongation test (type I only). Elongation tests (type I only) shall be performed in accordance with ASTM A391/A391M, ASTM A413/A413M, ASTM A466/A466M, or ASTM A467/A467M, as appropriate.

4.4.1.3 Proof test. Proof tests shall be performed in accordance with ASTM A391/A391M, ASTM A413/A413M, ASTM A466/A466M, or ASTM A467/A467M, as appropriate.

4.4.2 Attachments.

4.4.2.1 Type II, connecting links. Samples shall be subjected to the loads shown in the applicable tables either singly or in series. These tests shall be as specified in 4.4.1.1 and 4.4.1.3. If any sample link fails the proof or breaking test, the lot shall be rejected. Selected links for proof load shall be visually inspected to ensure that all links are interchangeable

without applying force. The two halves shall fit concentrically to each other and shall mate (face flush fit) to each other maintaining rivet-pin to hole alignment. The rivets shall be of sufficient diameter and length to completely fill countersunk holes when peened.

4.4.2.2 Type IV, shackles.

4.4.2.2.1 Proof test. Samples shall be subjected to proof loads shown in table VIII either singly or in series. The diameter of the attachments used in proofing shall be not greater than the pin diameter of the shackle being tested and the application of the proof load shall be at the center of the pin. After releasing the proof load, each shackle shall be examined and disassembled as specified in 3.4.3.1.2.

4.4.2.2.2 Breaking load and ductility tests. After proof testing, the required number of samples shall be subjected to the breaking load test to determine compliance with table VIII. The diameter of the attachment used in the breaking test shall be not greater than the pin diameter of the shackle being tested; the application of the load shall be at the center of the pin. After breaking, the sample shall be inspected and measured to determine conformance with 3.4.3.1.5.

4.4.2.2.3 Rejections. If any shackle fails to pass the proof load, breaking load, or ductility test, all shackles in the lot shall be rejected.

4.4.2.3 Type V, hooks, classes 1, 2, 3, and 6.

4.4.2.3.1 Proof test. Samples shall be subjected to the applicable proof loads provided in this specification. Hooks shall withstand the proof test without any noticeable permanent opening of the hook at the throat.

4.4.2.3.2 Breaking load and Ductility tests. Samples subjected to the breaking load strength test shall exhibit permanent deformation in the throat opening after failure.

4.4.2.3.3 Rejections. If any hook fails to pass the proof load, break load, or ductility tests, the lot shall be rejected.

4.4.2.4 Type VI, rings.

4.4.2.4.1 Proof test. Samples selected in accordance with 4.2.2.2.1 shall be subjected to the proof and breaking loads shown in table XVIII. Before testing, the inside diameter of the ring shall be measured perpendicular to the axis to which the load is to be applied. After applying the proof load, the diameter shall be remeasured and the sample shall be considered satisfactory if there is no measurable reduction in the diameter.

4.4.2.4.2 Breaking load test. Samples subjected to the breaking load test shall withstand the breaking loads shown in table XVIII.

4.4.2.4.3 Rejections. If any ring fails to pass the proof load or breaking load tests, all rings of the lot shall be rejected.

4.4.2.5 Type VII, swivels.

4.4.2.5.1 Proof load and breaking load test. Samples shall be subjected to the proof loads and breaking loads shown in tables XIX, XX, and XXI, either singly or in series. The swivels shall withstand the proof loads without developing surface rupture or defects that would interfere with serviceability.

4.4.2.5.2 Rejections. If any swivel fails to pass the proof or breaking load tests, all swivels in the lot shall be rejected.

4.4.2.6 Type XI, bead-chain insulating coupling dielectric strength test. Samples selected in accordance with table XXIX shall be tested for dielectric strength. One half of the samples shall be dried in a desiccator for 24 hours, removed, and immediately subjected to 10,000 volts. The remaining couplings shall be stored for 48 hours in an atmosphere of 35 °C (95 °F), 90 percent relative humidity, and immediately subjected to 4,000 volts. A tolerance of plus 1 hour and plus or minus 2 percent relative humidity will be permitted. The difference in potential for both samples shall be maintained for 1 minute.

4.4.2.7 Type XIII, pear-shaped links.

4.4.2.7.1 Proof test. Samples selected as specified in 4.2.2.2.1 shall be subjected to the proof loads as shown in table XXV. Before testing, the inside widths of the pear-shaped link shall be measured. After applying the proof load, the inside widths shall be re-measured and the sample shall be considered satisfactory if there is no measurable reduction in the inside widths.

4.4.2.7.2 Breaking load test. After proof testing, samples selected as specified in 4.2.2.2.1 shall be subjected to the breaking loads as shown in table XXV.

4.4.2.7.3 Rejections. If any link fails to pass the proof load or breaking load tests, the lot shall be rejected.

4.4.2.8 Type XIV mechanical coupling links.

4.4.2.8.1 Proof test. Samples selected as specified in 4.2.2.2.1 shall be subjected to the proof loads as shown in table XXVI. The mechanical coupling links shall be visually examined following proof load testing.

4.4.2.8.2 Breaking load test. After proof testing, samples selected as specified in 4.2.2.2.1 shall withstand the breaking loads as shown in table XXVI.

4.4.2.8.3 Rejections. There shall be no evidence of damage or deformation following proof load testing. If any mechanical coupling links fails to pass the proof load or breaking load tests, the lot shall be rejected.

4.4.2.9 Type XV end links.

4.4.2.9.1 Proof test. Samples selected as specified in 4.2.2.2.1 shall be subjected to the proof loads as shown in table XXVII. Before testing, the inside width of the end link shall be measured. After applying the proof load, the inside widths shall be re-measured and the sample shall be considered satisfactory if there is no measurable reduction in the inside width.

4.4.2.9.2 Breaking load test. After proof testing, samples selected as specified in 4.2.2.2.1 shall be subjected to the breaking loads as shown in table XXVII.

4.4.2.9.3 Rejections. If any sample link fails the proof or breaking test, the lot shall be rejected.

4.5 Inspection of packaging. Sample packs and the inspection of presentation, packing and marking for shipment, stowage, and storage shall be in accordance with the requirements of section 5.

5. PACKAGING

(The packaging requirements specified herein apply only for direct Government acquisition.)

5.1 Preservation. Preservation shall be level A or commercial, as specified (see 6.2).

5.1.1 Level A. Chain and attachments shall be preserved in accordance with method 30 (or greater) of MIL-STD-2073-1.

5.1.1.1 Chain weighing less than 35 pounds per 100 feet and attachments weighing less than 5 pounds each shall be packed in weather-resistant fiberboard boxes. The gross weight of the boxes shall not exceed the limitations of the applicable box specification.

5.1.1.2 Chain weighing in excess of 35 pounds per 100 feet and attachments weighing in excess of 5 pounds each shall be bulk-packed in containers as specified in 5.2.

5.1.2 Commercial. Chain and attachments shall be preserved in accordance with ASTM D3951.

5.2 Packing. Packing shall be method 30 (or greater) of MIL-STD-2073-1, or commercial as specified (see 6.2).

5.2.1 General requirements. Selected containers (see 5.2.2) shall be of minimum weight and cube consistent with the protection required, shall be of uniform size, and shall contain identical quantities, as appropriate.

5.2.2 Chains and attachments. Chain and attachments preserved as specified (see 5.1) shall be packed in exterior shipping containers in accordance with MIL-STD-2073-1, method 30, for the level of packing specified (see 5.2). Unless otherwise specified (see 6.2), container selection including container options shall be the contractor's option.

5.2.2.1 Closures, gross weight, and waterproofing.

5.2.2.1.1 Closure. Container closure, reinforcing, or banding shall be in accordance with the applicable container specification, except that weather-resistant fiberboard boxes shall be closed and reinforced with non-metallic or tape banding; and domestic non-weather-resistant fiberboard boxes shall be closed using pressure sensitive tape.

5.2.2.1.2 Weight. Wood, plywood, and wood-cleated type containers exceeding 200 pounds gross weight shall be modified by the addition of skids in accordance with MIL-STD-2073-1, or the applicable container specification.

5.2.2.1.3 Waterproofing. Unless otherwise specified (see 6.2), shipping containers shall be provided with case liners, linings, wraps, or shrouds.

5.2.3 Commercial. Chain and attachments preserved as specified (see 5.1) shall be packed for shipment in accordance with ASTM D3951 and herein.

5.2.3.1 Container modification. Shipping containers exceeding 200 pounds gross weight shall be provided with a minimum of two, 3 x 4-inch nominal wood skids laid flat; or a skid or sill-type base which will support the material and facilitate handling by mechanical handling equipment during shipment, stowage, and storage.

5.3 Palletized unit loads. When specified (see 6.2), containers shall be palletized in accordance with MIL-STD-2073-1.

5.4 Marking.

5.4.1 Chains and attachments. In addition to any special marking required (see 6.2), interior (unit) packs, shipping containers, and palletized unit loads shall be marked in accordance with MIL-STD-2073-1 for military agencies and FED-STD-123 for civil agencies and shall include barcodes and applicable packaging acquisition options herein as specified herein (see 6.2).

6. NOTES

INFORMATION FOR GUIDANCE ONLY. (This section contains information of a general or explanatory nature that is helpful, but is not mandatory.)

6.1 Intended use.

6.1.1 Type I, chain, welded steel. Type I is steel chain intended for general service. Type I, class 1, is a special analysis alloy steel recommended for hazardous overhead lifting and wherever long life and extremely high tensile strengths are desired. Type I, class 2, is a special analysis steel treated as required to produce a chain having high tensile strength and resistance to impact loads.

6.1.2 Type II, chain, weldless. Type II, class 11, mechanical communication chain is intended for use in pulleys used on a line of signal transmission of mechanical telegraphs, i.e. ship's bridge to engine room communication.

6.1.3 Type IV, shackles. Shackles, with the exception of class 1 round pin and cotter, are intended for general use including rigging.

6.1.4 Type XV, end links. End links in accordance with this specification are intended for use with fueling at sea rigging.

6.2 Acquisition requirements. Acquisition documents should specify the following:

- a. Title, number, and date of this specification.
- b. Type, class, and style of chain; and type, grade, and class of attachments required (see 1.2.1 and 1.2.2).
- c. Material required for type II, classes 1, 2, 3, 4, 6, 7, 8, 9, and 10 chains (see 3.1.2).
- d. Material required for type II, class 5 bead chain, and type IX, X, and XI fasteners/couplings (see 3.1.3).
- e. Finish required, if other than that specified (see 3.2 and 3.4.3.1.7).
- f. Finish specific to type I chain (see 3.2.1.1).
- g. Finish specific to type II chain (see 3.2.1.2).
- h. Finish specific to attachments (see 3.2.1.3).
- i. Fine threads for shackles, if required (see 3.4.3.1.1).
- j. Form and dimensions (3.4.3.2).
- k. AQL (see 4.2.2.2.1).
- l. Size of chain or attachments required (see applicable tables).
- m. Whether purchasing type I or type II chain by the foot.
- n. Level of preservation, packaging, and packing required (see 5.1 and 5.2).
- o. Shipping method for single chain lengths exceeding 1000 pounds net weight (see 5.2).
- p. Container selection, if not contractor's option (see 5.2.2).
- q. Waterproofing packaging requirements, other than specified (5.2.2.1.3).
- r. When palletization is required (see 5.3).
- s. Special marking, if required (see 5.4).

6.3 Subject term (key word) listing.

Alloy chain
Anchor shackle
Appendage
Barrel hook
Breaking load
Double jack
Ductility
End link
Eye swivel
Grab hook
Ground tackle

Hook
Insulating coupling
Pear-shaped
Proof load
Register chain
Plumber's chain
Sash chain
Shackle
Single jack
Sling hook
Slip hook
Swivel

6.4 Changes from previous issue. Asterisks (or vertical lines) are not used in this revision to identify changes with respect to the previous issue due to the extensive changes.

MILITARY INTERESTS:

Custodians:

Navy - SH
Air Force - 99
DLA - GS

Review Activities:

Air Force - 71
Other - DS

CIVIL AGENCY
COORDINATING ACTIVITY:

GSA - FAS

Preparing Activity:

DLA - GS5

(Project 4010-2010-006)

NOTE: The activities listed above were interested in this document as of the date of this document. Since organizations and responsibilities can change, you should verify the currency of the information above using the ASSIST database at <https://assist.daps.dla.mil/>.